

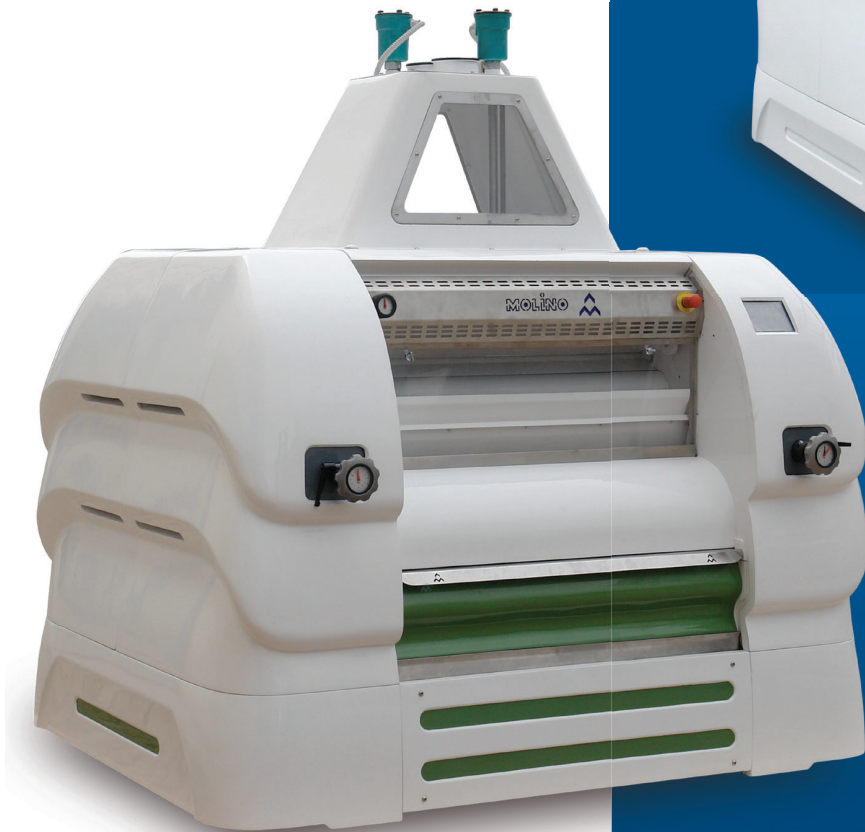

molitus®

06

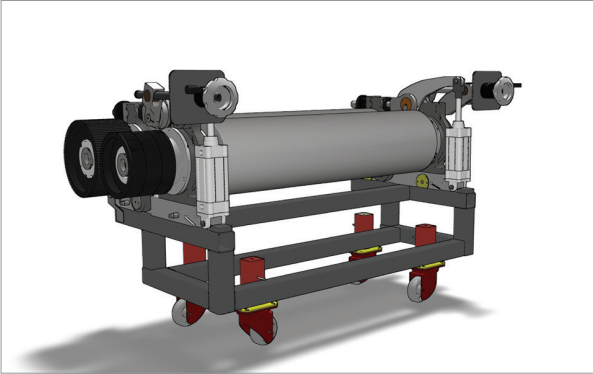

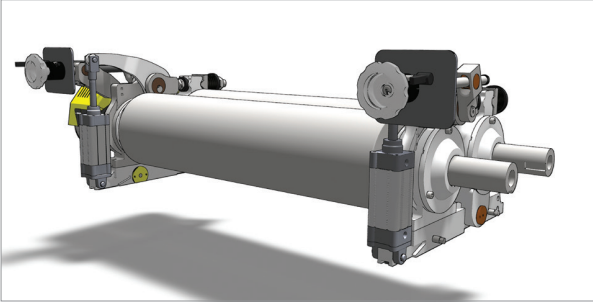

- Hızlı Top Değişirme
- Easy Fast roll change
- Facilité et rapidité du changement des rouleaux

- Gelişmiş mekanizma ve otomasyon
- Improved mechanisms and automation
- Amélioration du mécanisme et de l'automatisation

molitus®

07

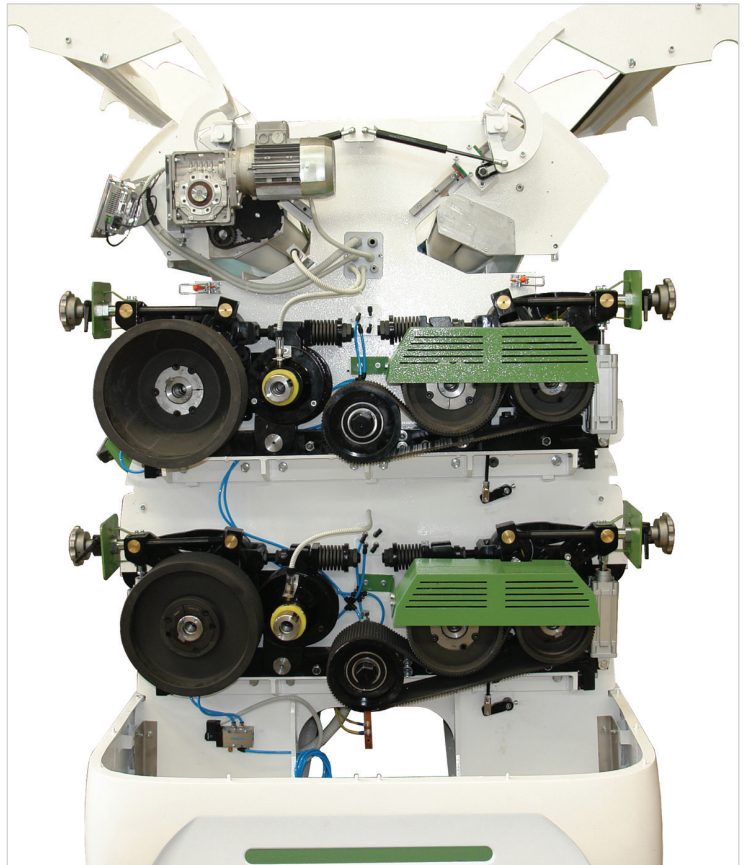
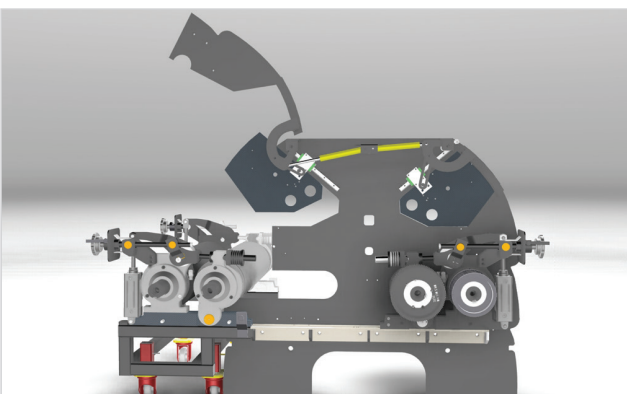
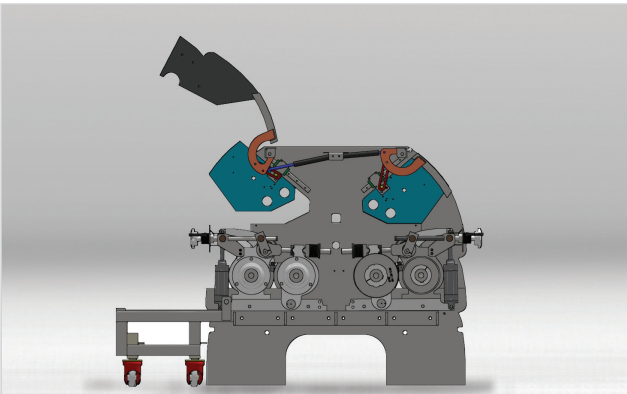



08

- Yüksek teknoloji ve mühendislik.
- Hi-Tec & Stated - the - art.
- Haute technologie et ingénierie.

- Hızlı, kolay erişilebilirlik ve bakım.
- Quick, easy accesibility and maintenance.
- Rapidité, facilité d'accès et entretien.

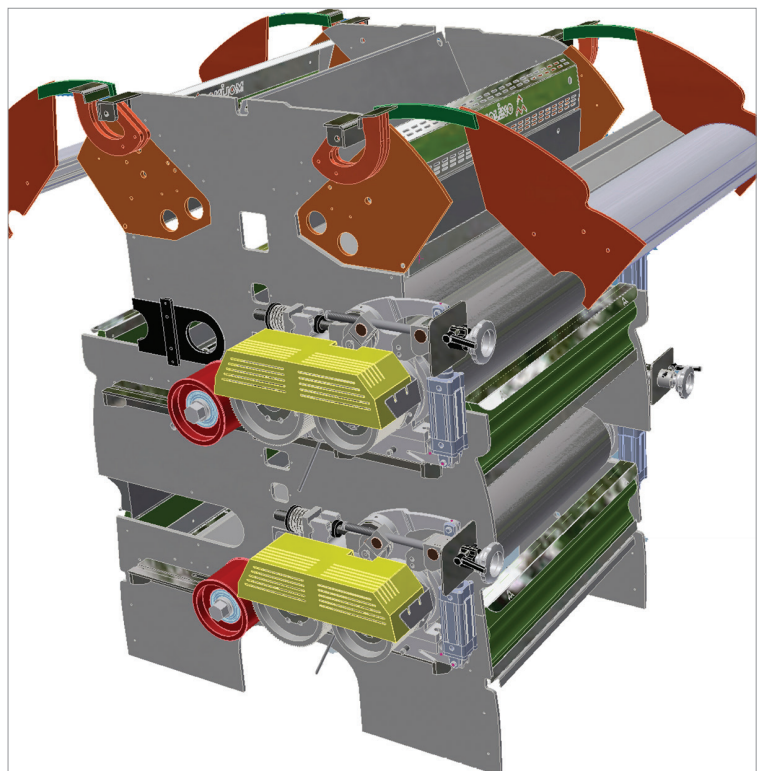
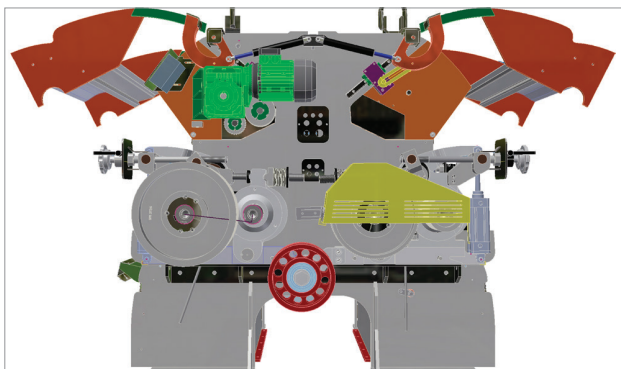
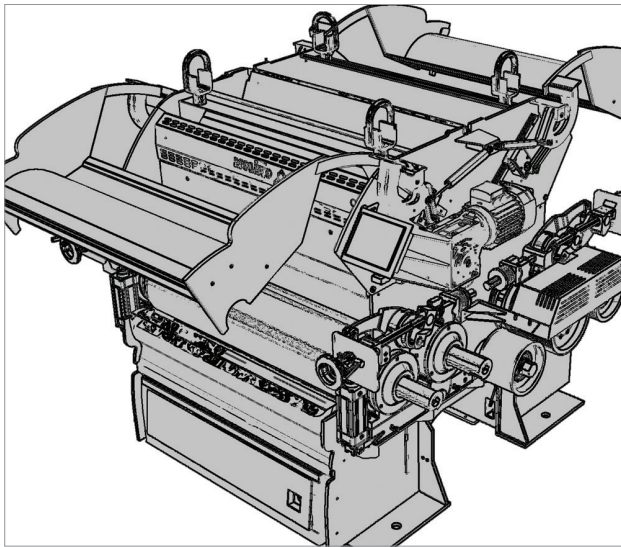

VALS / ROLLER MILL / APPAREIL A CYLINDRES

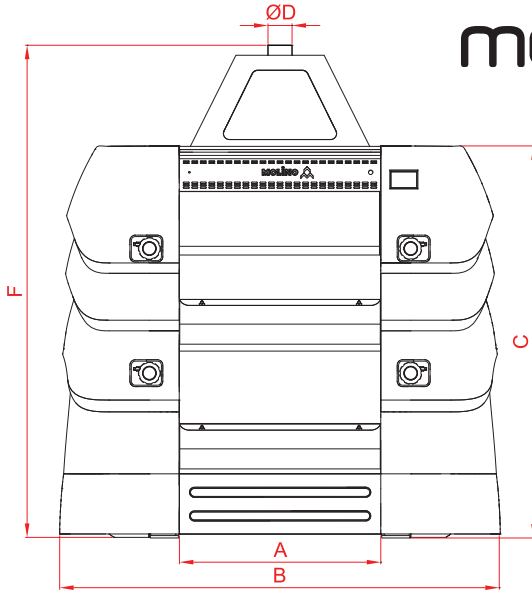
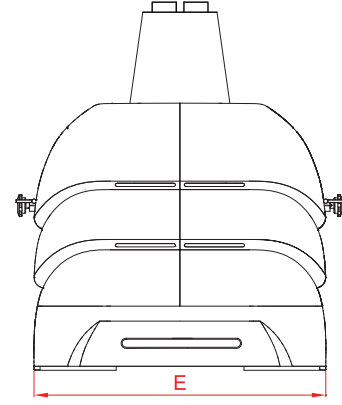
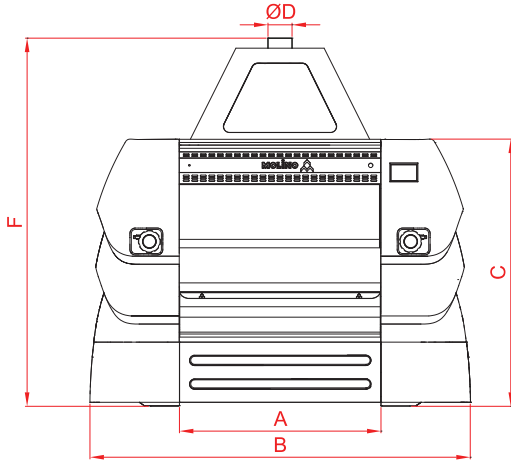

molitus®

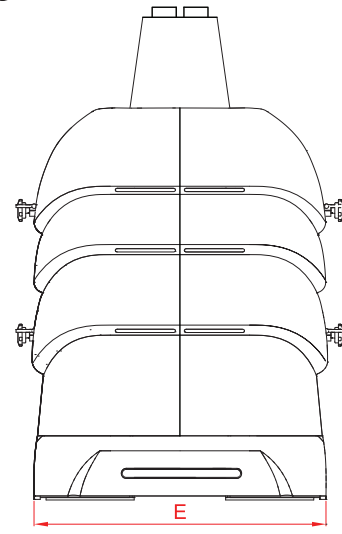

09

ÖLÇÜLER - DIMENSIONS (mm)

Tip / Type	A	B	C	ØD	E	F
Mud-32-M-80-25	805	1697	1332	120-150	1455	1836
Mud-32-M-100-25	1005	1897	1332	120-150	1455	1836
Mud-32-M-100-30	1005	1897	1332	120-150	1555	1836
Mud-32-M-125-25	1255	2147	1332	120-150	1455	1836
Mud-32-M-125-30	1255	2147	1332	120-150	1555	1836
Mud-32-M-100D-25	1005	2197	1953	120-150	1455	2457
Mud-32-M-100D-30	1005	2197	1953	120-150	1555	2457
Mud-32-M-125D-25	1255	2447	1953	120-150	1455	2457
Mud-32-M-125D-30	1255	2447	1953	120-150	1555	2457

TEKNİK BİLGİLER - TECHNICAL DATA

Tip / Type	Top Çapı Roll Diameter (mm)	El. Motoru El. Motor (kW)	Ağırlık Weight (kg)
Mud-32-M-80-25	250	2x(3 - 15)	2570
Mud-32-M-100-25	250	2x(5.5 - 22)	2920
Mud-32-M-100-30	300	2x(5.5 - 22)	2920
Mud-32-M-125-25	250	2x(7.5 - 37)	3320
Mud-32-M-125-30	300	2x(7.5 - 37)	3320
Mud-32-M-100D-25	250	4x(5.5 - 22)	5100
Mud-32-M-100D-30	300	4x(5.5 - 22)	5100
Mud-32-M-125D-25	250	4x(7.5 - 37)	5250
Mud-32-M-125D-30	300	4x(7.5 - 37)	5250



VALS / ROLLER MILL / APPAREIL A CYLINDRES



- Monoblok Döküm Gövde
- Monoblock cast steel body
- Corps monobloc en tôle d'acier

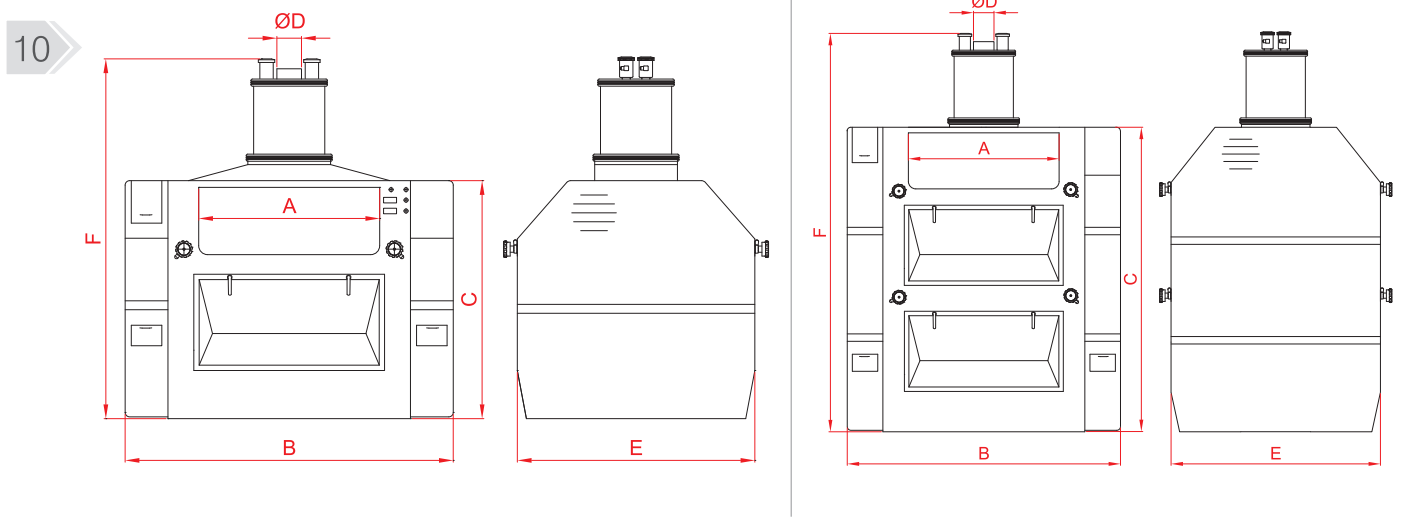

ÖLÇÜLER - DIMENSIONS (mm)						
Tip / Type	A	B	C	ØD	E	F
Mud-05-AE-60-25	610	1510	1340	120-150	1385	2090
Mud-05-AE-80-25	810	1710	1340	120-150	1385	2090
Mud-05-AE-100-25	1010	1910	1340	120-150	1385	2090

ÖLÇÜLER - DIMENSIONS (mm)						
Tip / Type	A	B	C	ØD	E	F
Mud-05-AE-100D-25	1010	2025	1940	120-150	1355	2510

TEKNİK BİLGİLER - TECHNICAL DATA			
Tip / Type	Top Çapı Roll Diameter (mm)	El. Motoru El. Motor (kW)	Ağırlık Weight (kg)
Mud-05-AE-60-25	250	2x(3 - 15)	3900
Mud-05-AE-80-25	250	2x(5.5 - 22)	4300
Mud-05-AE-100-25	250	2x(7.5 - 37)	4800
Mud-05-AE-100D-25	250	4x(7.5 - 37)	7800

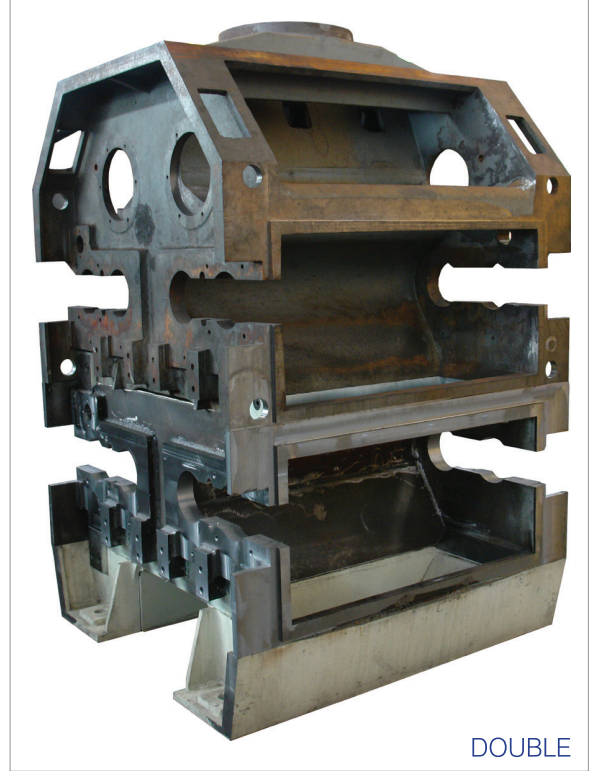
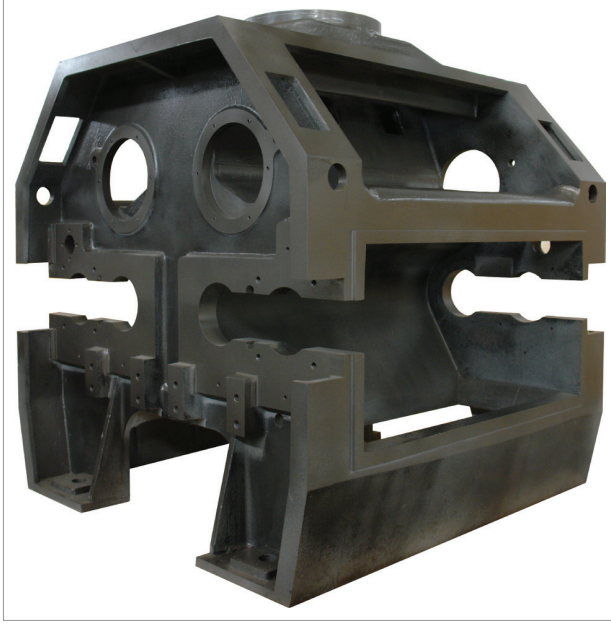

DOUBLE



- Monoblok Döküm Gövde
- Monoblock cast steel body
- Corps monobloc en fonte

- Güçlü, sağlam ve stabil konsept
- Sturdy stable and strong concept
- Robuste, stable et solide

11

