

İPEK GERİCİ / SIEVE STRETCHER / TAMISEUR A AIR COMPRIME

18

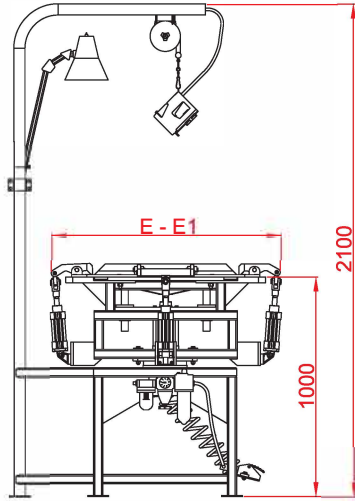

TEKNİK BİLGİLER - TECHNICAL DATA

Tip / Type	Hava İhtiyacı Air required (m ³ /min)	Basınç İhtiyacı Pressure required (bar)	Ağırlık Weight (kg)
Ms-52-A	0.1	6 - 7	185
Ms-52-B	0.1	6 - 7	220
Ms-52-C	0.1	6 - 7	250

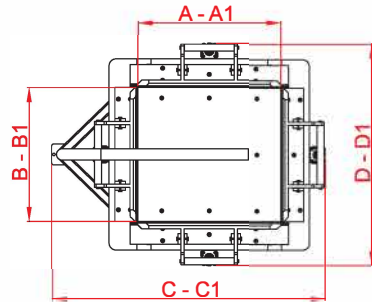

ÖLÇÜLER - DIMENSIONS (mm)

Tip / Type	A	A1	B	B1	C	C1	D	D1	E	E1
Ms-52-A	575	620	500	575	1375	1420	880	955	955	1000
Ms-52-B	670	670	720	590	1470	1280	1000	970	1050	1050
Ms-52-C	745	745	798	660	1545	1545	1178	1040	1125	1125